

Assessment of drought tolerance in land races of bread wheat based on resistance/ tolerance indices

Ezatollah Farshadfar*, Mohammad Mehdi Poursiahbidi, Seyed Mehdi Safavi

Campus of Agriculture and Natural Resources, Razi University, Kermanshah, Iran

*Corresponding Author E-mail: e_farshadfar@yahoo.com

Received: 18 September 2018, Revised: 24 October 2018, Accepted: 30 October 2018

ABSTRACT

One of the possible ways to ensure future food needs of an increasing world population involves the better water use through the development of crop varieties which need less water and are more tolerant to drought. In order to study the response of twenty landraces of bread wheat to drought stress, an experiment was conducted in a randomized complete block design with three replications under two irrigated and water stress conditions during 2010-2011 cropping season. Sixteen drought tolerance indices including stress tolerance index (STI), stress susceptibility index (SSI), tolerance index (TOL), harmonic mean (HM), geometric mean productivity (GMP), mean productivity (MP), yield index (YI), yield stability index (YSI), sensitive drought index (SDI), drought resistance index (DI), abiotic tolerance index (ATI), relative decrease in yield index (RDY), stress non-stress production index (SNPI), modified stress tolerance index (MSTI), relative drought index (RDI) and stress susceptibility percentage index (SSPI) were calculated based on grain yield under drought (Y_s) and irrigated (Y_p) conditions. Grain yield in stress (Y_s) condition was significantly and positively correlated with STI, GMP, MP, HM, YI, DI, RDI, YSI, SNPI, K_1 STI and K_2 STI. Grain yield in non-stress (Y_p) condition was significantly and positively correlated with STI, MP, GMP, HM, YI, DI, ATI, K_1 STI, K_2 STI and SNPI. Grain yield in stress and non-stress conditions was significantly and negatively correlated with SSI. The results of this study showed that the indices K_1 STI, K_2 STI, SSPI, RDI, ATI, SNPI, and DI can be used as the most suitable indicators for screening drought tolerant cultivars. Cluster analysis classified the genotypes into three groups i.e., tolerant, susceptible and semi-tolerant or semi-sensitive to drought conditions. Therefore, they are recommended to be used as parents for improvement of drought tolerant cultivars.

Keyword: Land races of bread wheat, Drought tolerant indices, Principal component analysis

INTRODUCTION

In arid and semiarid regions with Mediterranean climate, wheat crops usually encounter drought during the grain filling period. Drought is one of the most damaging abiotic stresses affecting agriculture. It is an important abiotic factor affecting the yield and yield stability of food cereals and acts simultaneously on many traits leading to a decrease in yield (Boyer, 1982; Ludlow and Muchow, 1990; Abebe *et al.*, 2003; Zhang *et al.*, 2006). Breeding for resistance to drought is complicated by the lack of fast, reproducible screening techniques and the inability to routinely create defined and repeatable water stress conditions where large populations can be evaluated efficiently (Ramirez and Kelly, 1998). Iran is located on the world's desert belt, and is considered

as an arid and semiarid region. Average rainfall in the country is about 250 (mm) which is one third of average rainfall in the world, while 1.2 percent of the world's land is allocated to Iran. On the other hand, of 18.5 million hectares of agricultural lands, 6.2 million hectares (33.5 %) is devoted to dry cultivation. About 1.2 million /ha of lands under dry cultivation, will receive more than 400 (mm) rainfall. (Mohammadi *et al.*, 2006). Loss of yield is the main concern of plant breeders and they hence emphasize on yield performance under stress conditions. Thus, drought indices which provide a measure of drought based on loss of yield under drought-conditions in comparison to normal conditions have been used for screening drought-tolerant genotypes (Mitra, 2001). Various researchers have used different methods to evaluate genetic differences in drought tolerance. Drought resistance is defined by Hall (1993) as the relative yield of a genotype compared to other genotypes subjected to the same drought stress. Drought susceptibility of a genotype is often measured as a function of the reduction in yield under drought stress, whilst the values are confounded with differential yield potential of genotypes (Ramirez and Kelly, 1998). Several selection criteria have been proposed to select genotypes based on their performance in stress and non-stress environments. Fischer *et al.*, (1998) suggested that relative drought index (RDI) is a positive index for indicating stress tolerance. Lan (1988) defined a new index of drought resistance index (DI), which was commonly accepted to identify genotypes producing high yield under both stress and non-stress conditions. Rosielle and Hamblin (1981) defined stress tolerance (TOL) as the differences in yield between stress and irrigated environments and mean productivity (MP) as the average yield of genotypes under stress and non-stress conditions. The geometric mean productivity (GMP) is often used by breeders interested in relative performance, since drought stress can vary in severity in field environments over years (Fernandez, 1992). Fischer and Maurer (1978) suggested the stress susceptibility index (SSI) for measurement of yield stability that apprehended the changes in both potential and actual yields in variable environments. Clarke *et al.*, (1992) used SSI to evaluate drought tolerance in wheat genotypes and found year-to-year variation in SSI for genotypes and could rank their pattern. In spring wheat cultivars, Guttieri *et al.*, (2001), using SSI, suggested that an SSI > 1 indicated above-average susceptibility to drought stress. The yield index (YI; suggested by Gavuzzi *et al.*, 1997) and yield stability index (YSI) suggested by Bousslama and Schapaugh (1984) in order to evaluate the stability of genotypes in the both stress and non-stress conditions. Stress tolerance index (STI) was defined as a useful tool for determining high yield and stress tolerance potential of genotypes (Fernandez, 1992). To improve the efficiency of STI a modified stress tolerance index (MSTI) was suggested by Farshadfar and Sutka (2002) which corrects the STI as a weight. Moosavi *et al.*, (2008) introduced stress susceptibility percentage index (SSPI), stress non-stress production index (SNPI) and abiotic tolerance index (ATI) for screening drought tolerant genotypes in stress and non-stress conditions. The present study was therefore undertaken (i) to screen drought tolerance criteria and (ii) selection of drought tolerant landraces of bread wheat in Iran.

MATERIALS AND METHODS

Experimental Design and Plant Material

Twenty landraces of bread wheat listed in Table 1 were assessed using a randomized complete block design with three replications under two irrigated and water stress conditions during 2010 - 2011 growing season at the Research Farm of Campus of Agriculture and Natural Resources, Razi University, Kermanshah, Iran (47° 20' N latitude, 34° 20' E longitude and 1351.6 m altitude). Climate in the region is classified as semiarid. Minimum and maximum temperature at

the research station were -27°C and 44°C , respectively. The climate is characterized by mean annual precipitation of 478 mm, mean annual temperature of 35°C . Sowing was done by hand in plots with four rows 2 m in length and 25 cm apart. At the rainfed experiment, water stress was imposed after anthesis. Non-stressed plots were irrigated three times after anthesis, while stressed plots received no water. At harvest time, yield potential (Y_p) and stress yield (Y_s) were measured from 2 rows 1 m in length.

Calculation of Indices

Sixteen drought tolerance indices were calculated using the following relationships (Fischer and Maurer, 1978; Fischer *et al.*, 1998; Fernandez, 1992; Rosielle & Hamblin, 1981; Bouslama & Schapaugh, 1984; Lan, 1998; Moosavi *et al.*, 2008; Farshadfar & Sutka, 2002):

1-SSI = $(1 - (Y_s/Y_p))/(1 - ((\bar{Y}_s)/(\bar{Y}_p)))$, $1 - ((\bar{Y}_s)/(\bar{Y}_p))$ is the stress intensity. The genotypes with $SSI < 1$ are more resistant to drought stress conditions.

2-STI = $(Y_s \times Y_p)/(\bar{Y}_p)^2$, the genotypes with high STI values will be tolerant to drought stress.

3-GMP = $\sqrt{(Y_s)(Y_p)}$, the genotypes with high value of this index will be more desirable.

4-MP = $(Y_s + Y_p)/2$, the genotypes with high value of this index will be more desirable.

5-TOL = $Y_p - Y_s$, the genotypes with low values of this index are more stable in two different conditions.

6-HM = $[2(Y_p)(Y_s)]/(Y_p + Y_s)$, the genotypes with high HM value will be more desirable.

7-YI = Y_s/\bar{Y}_p , the genotypes with high value of this index will be suitable for drought stress condition.

8-YSI = Y_s/Y_p , the genotypes with high YSI values can be regarded as stable genotypes under stress and non-stress conditions.

9-SDI = $(Y_p - Y_s)/Y_p$, the genotypes with low value of this index will be more desirable.

10-DI = $[Y_s \times (Y_s/Y_p)]/\bar{Y}_s$

11-RDY = $100 - (Y_s/Y_p \times 100)$

12-ATI = $[(Y_p - Y_s)/(\bar{Y}_s/\bar{Y}_p)] \times [\sqrt{Y_p \times Y_s}]$

13-SSPI = $[Y_p - Y_s/(2\bar{Y}_p)] \times 100$

14-SNPI = $[(Y_p + Y_s)/(Y_p - Y_s)]^{1/3} \times [Y_p \times Y_s \times Y_s]^{1/3}$

15-MSTI = K_1STI , $K_1 = (Y_p)^2/(\bar{Y}_p)^2$ and $K_2 = (Y_s)^2/(\bar{Y}_s)^2$

16-RDI = $(Y_s/Y_p)/(\bar{Y}_s/\bar{Y}_p)$

Where, Y_s and Y_p represent yield in stress and non-stress conditions respectively. Also, \bar{Y}_s and \bar{Y}_p are mean yield of all genotypes in stress and non-stress conditions respectively. The genotypes can be categorized into four groups based on their performance in stress and non-stress environments: cultivars express uniform superiority in both stress and non-stress conditions (Group A), cultivars perform favorably only in non-stress conditions (Group B), cultivars gives relatively higher yield only in stress conditions (Group C), and cultivars perform poorly in both stress and non-stress conditions (Group D). The optimal selection criterion should distinguish Group A from the other three groups. Three-dimensional plots among Y_s , Y_p , and STI, showed the interrelationships among these three variables to separate cultivars of Group A from other groups (Fernandez, 1992).

Statistical Analysis

Correlation among indices and grain yield in two conditions, cluster analysis, and three-dimensional plots drawing were performed by SPSS ver.20, Statistica ver.8, respectively.

RESULTS AND DISCUSSION

Comparing genotypes based on the resistance/tolerance indices

To investigate suitable stress resistance indices for screening of genotypes under drought condition, grain yield of cultivars under both non-stress and stress conditions were measured for calculating different sensitivity and tolerance indices (Table 2). A suitable index must have a significant correlation with grain yield under both the conditions (Mitra, 2001). Based on the stress tolerance index (STI) and grain yield, 4, 7, 8 and 19 were found drought tolerance with the highest STI and grain yield under irrigated (non-stressed) condition, while 14 and 20 displayed the lowest amount of STI and grain yield under irrigated condition. Other entries were identified as semi-tolerance or semi-sensitive to drought stress (Table 2). Rosielle and Hamblin (1981) reported that stress tolerance index and mean productivity were defined as the difference in yield and the average yield between stress and non-stress conditions, respectively. Thus, the highest GMP and MP were related to the accessions 4, 7 and 8. According to tolerance index (TOL), 19, 11, 5 and 18 exhibited the most and 17, 9, 7 and 16 the least relative tolerance, respectively. The highest HM was related to landraces 4, 7 and 8. Mevlut and Sait (2011) indicated that the genotypes with high STI usually have high difference in yield in two different conditions. They reported in general, similar ranks for the genotypes were observed by GMP and MP parameters as well as STI, which suggests that these three parameters are equal for screening drought tolerant genotypes. For stress susceptibility index (SSI) and relative drought index (RDI) the genotypes 17, 7, 9, 16 and 4 were the most relative tolerant genotypes. According to yield index (YI), 4, 7, 8, 17 and 16 were discriminated as the most relative tolerant genotypes. However, the entries 17, 7, 16 and 6 were characterized as desirable genotypes according to the yield stability index (YSI). With regard to K₁STI and K₂STI the landraces 4, 7, 8, 17 and 19 were the most relative tolerant. Genotypes 17, 9, 3 and 2 displayed relative high abiotic tolerant index (ATI) and stress susceptibility percentage index (SSPI), while genotypes 19, 11 and 5 showed the lowest amount of ATI and SSPI. Also, with regard to drought resistance index (DRI) and stress non-stress production index (SNPI) genotypes 4, 7, 16 and 17 were the most relative tolerant. The lowest amount of relative decrease in yield was attributed to genotypes 4 and 7. Ilker *et al.*, (2011) concluded that MP, GMP and STI values are convenient parameters to select high yielding wheat genotypes in both stress and non-stress conditions whereas relative decrease in yield, TOL and SSI values are better indices to determine tolerance levels.

Correlation Analysis

To determine the most desirable drought tolerant criteria, the correlation coefficients between Y_p, Y_s and other quantitative indices of drought tolerance were calculated (Table 3). In other words, correlation analysis between grain yield and drought tolerance indices can be a good criterion for screening the best cultivars and indices used. Grain yield in stress condition (Y_s) was significantly and positively correlated with STI, GMP, MP, HM, YI, YSI, SNPI, RDI, DI, K₁ and K₂ and negatively correlated with SSI. Yield in non-stress condition (Y_p) was significantly and positively correlated with STI, GMP, MP, HM, YI, SNPI, ATI, K₁, K₂ and DI indicating that these criteria were more effective in identifying high yielding cultivars under different water conditions. Toorchi *et al.*, (2012) showed that correlation between MP, GMP, Y_s and Y_p was

positive. Dehghani *et al.*, (2009) reported that GMP, MP and STI were significantly and positively correlated with stress yield. Farshadfar *et al.*, (2001) believed that the most appropriate index for selecting stress tolerant cultivars is an index which has partly high correlation with seed yield under stress and non-stress conditions. In the study conducted by Farshadfar and Elyasi (2012), grain yield in the stress and non-stress conditions were positively correlated with YSI, YI, DRI, MSTI, RDI. In generally, the observed relations were consistent with those reported by Toorchi *et al.*, (2012) in canola, Golabadi *et al.*, (2006) in durum wheat, Khalili *et al.*, (2012) in canola and Farshadfar *et al.*, (2012) in bread wheat. Ehdaie and Shakiba (1996) found in wheat that there was no correlation between stress susceptibility and yield under optimum condition.

Principal component analysis

To better understand the relationships, similarities and dissimilarities among drought tolerance indices, principal component analysis (PCA), based on the indices correlation matrix was used. The main advantage of using PCA over cluster analysis is that each statistics can be assigned to one group only. The relationships among different indices are graphically displayed in a biplot of PCA₁ and PCA₂ (Fig. 1). The PCA₁ and PCA₂ axes which justify 99.6% of total variation, mainly distinguish the indices in different groups. Indices RDI and YSI we refer to group 1. The PCs axes separated SNPI, DI, STI, YI, DI, K1STI, K2STI, GMP, MP, HM, Ys and Yp in group 2. ATI was separated as groups 3. TOL, SSPI, SDI and SSI were separated as groups 4 and RDY in group 5.

Three dimensional plots and cluster analysis

In order to identify drought tolerant cultivars, three dimensional plots based on Yp, Ys, GMP and STI were drawn (Fig. 2 and 3). Three dimensional plots are presented to show the interrelationships among these three variables to separate the cultivars of group A (high yielding cultivars in both stress and non-stress conditions) from the other groups (B, C and D), and to illustrate the advantage of STI and GMP indices as selection criterion for identifying high-yielding and stress tolerant cultivars. In three dimensional plots, 4, 7, 8, 19, 16, 19 and 17 were included in A group, these accessions revealed stable grain yield in stress and non-stress conditions. The genotypes 20, 14, 18, 11, 9, 15, 13 were in D group that performed poorly in both conditions. Cluster analysis showed that the cultivars, based on indices tended to group into three groups: tolerant, semi-tolerant and sensitive genotypes. (Fig. 4). In this analysis, the first group had the highest Yp, Ys, STI, MP, GMP, YI, DI, K1STI, K2STI, and SNPI and was thus considered to be the most desirable cluster for both growth conditions (tolerant group). The second group had mean indicators values (Semi- sensitive/ semi-tolerant). In the third group, all cultivars had high SSI, thus they were susceptible to drought and only suitable for irrigated conditions.

CONCLUSION

In conclusion, based on principal component and biplot analysis, the indices of group 2 (G2) STI, MP, GMP, YI, DI, K1STI, K2STI, and SNPI exhibited strong correlation (acute angles) with Ys and Yp, therefore, they can discriminate drought tolerant genotypes with high grain yield at the same manner under stress and nonstress conditions (group A of Fernandez). With regard to these indices and cluster analysis, genotypes 4 (Wc-4937), 6 (WC-4924), 7 (WC-4888), 8 (WC-4823), 16 (WC-4992), 17 (WC-4995) and 19 (WC-Shahryar) were the most drought tolerant genotypes.

REFERENCES

- Abebe, T., Arro, C.G., Bjorn, M., John, C.C. (2003). Tolerance of mannitol-accumulating transgenic wheat to water stress and salinity. *Plant Physiology*, 131:1748-1755.
- Bouslama, M., Schapaugh, W.T. (1984). Stress tolerance in soybean. Part 1: evaluation of three screening techniques for heat and drought tolerance. *Crop Science*, 24:933-937.
- Boyer, J.S. (1982): Plant productivity and environments. *Science*, 218:443-448.
- Clarke, J.M., DePauw, R.M., Townley Smith, T.F. (1992). Evaluation of methods for quantification of drought tolerance in wheat. *Crop Science*, 32:423-428.
- Dehghani, G.H., Malekshhi, F., Alizadeh, B. (2009). A Study of Drought Tolerance Indices in Canola (*Brassica napus L.*) Genotypes. *Journal of Science and Technology of Agriculture and Natural Resources*, 13(48):77-90.
- Ehdaie, B., Shakiba, M.R. (1996). Relationship of inter node specific weight and water-soluble carbohydrates in wheat. *Cereal Research Communication*, 24:61-67.
- Farshadfar, E., Elyasi, P. (2012). Screening quantitative indicators of drought tolerance in bread wheat (*Triticum aestivum L.*) landraces. *European Journal of Experimental Biology*, 2(3):577-584.
- Farshadfar, E., Pour Siahbidi, M.M., Pour Abooghadareh, A.R. (2012). Repeatability of drought tolerance indices in bread wheat genotypes. *International Journal of Agriculture and Crop Science*, 4(13):891-903.
- Farshadfar, E., Sutka, J. (2002). Multivariate analysis of drought tolerance in wheat substitution lines. *Cereal Research Communication*, 31: 33-39.
- Farshadfar, E., Ghannadha, M., Zahravi, M., Sutka, J. (2001). Genetic analysis of drought tolerance in wheat. *Plant Breeding*, 114: 542-544.
- Fernandez, G.C.J. (1992). Effective selection criteria for assessing plant stress tolerance. In: Kuo CG (ed) *Proceedings of the International Symposium on Adaptation of Vegetables and other Food Crops in Temperature and Water Stress*, Publication, Tainan, Taiwan.
- Fischer, R.A., Maurer, R. (1978). Drought resistance in spring wheat cultivars. I. Grain yield responses. *Australian Journal of Agricultural Research*, 29:897-912.
- Fischer, R.A., Rees, D., Sayre, K.D., Lu, Z.M., Condon, A.G., Saavedra, A.L. (1998). Wheat yield progress associated with higher stomatal conductance and photosynthetic rate, and cooler Canopies. *Crop Science*, 38:1467-1475.
- Gavuzzi, P., Rizza, F., Palumbo, M., Campalino, R.G., Ricciardi, G.L., Borghi, B. (1997). Evaluation of field and laboratory predictors of drought and heat tolerance in winter cereals. *Plant Science*, 77:523-531.
- Golabadi, M.A., Arzani, S.A., Maibody, M. (2006). Assessment of drought tolerance in segregating populations in durum wheat. *African Journal of Agricultural Research*, 1(5):62-171.

- Guttieri, M.J., Stark, J.C., Brien, K., Souza, E. (2001). Relative sensitivity of spring wheat grain yield and quality parameters to moisture deficit. *Crop Science*, 41:327-335.
- Hall, A.E. (1993). Is dehydration tolerance relevant to genotypic differences in leaf senescence and crop adaptation to dry environments? In: Close TJ and Bray EA (Eds) *Plant Responses to cellular Dehydration during environmental stress*, 1-10.
- Ilker, E., Tatar, O., Aykut Tonk, F., Tosun, M., Turk, J. (2011). Determination of Tolerance Level of Some Wheat Genotypes to Post-Anthesis Drought. *Turkish Journal of Field Crops*, 16(1):59-63.
- Khalili, M., Naghavi, M.R, Pour Aboughadareh, A.R, Talebzadeh, S.J. (2012). Evaluating of drought stress tolerance based on selection indices in spring canola cultivars (*Brassica napus* L.). *Journal of Agricultural Science*, 4(11):78-85.
- Lan, J. (1998), Comparison of evaluating methods for agronomic drought resistance in crops. *Acta Agric Boreali-occidentalis Sinica* 7: 85–87.
- Ludlow, M.M., Muchow, R.C. (1990): A critical evaluation of traits for improving crop yields in water-limited environment. *Advances in Agronomy*, 43:107-153.
- Mevlut, A., Sait, C. (2011). Evaluation of drought tolerance indices for selection of Turkish oat (*Avena sativa* L.) landraces under various environmental conditions. *Zemdirbyste Agriculture*, 98 (2):157-166.
- Mitra, J. (2001). Genetics and genetic improvement of drought resistance in crop plants. *Current Science*, 80:758-762.
- Mohammadi, R., Haghparast, R., Aghaei Sarbarzeh, M., Abdollahi, A. (2006). Evaluation of drought tolerance rate of advanced genotypes of Durum wheat on the basis of physiologic standards and other related indices. *Iranian Agricultural Sciences*, 3 (1): 561-567.
- Moosavi, S.S., Yazdi Samadi, B., Naghavi, M.R, Zali, A.A, Dashti, H., Pourshahbazi, A. (2008). Introduction of new indices to identify relative drought tolerance and resistance in wheat genotypes. *Desert*, 12:165-178.
- Ramirez, P., Kelly, J. (1998). Traits related to drought resistance in common bean. *Euphytica*, 99:127-136.
- Rosielle, A.A, Hamblin, J. (1981). Theoretical aspects of selection for yield in stress and non-stress environments. *Crop Science*, 21:943-946.
- Toorchi, M., Naderi, R., Kanbar, A., Shakiba, M.R. (2012). Response of spring canola cultivars to sodium chloride stress. *Annals of Biological Research*, 2(5):312-322.
- Zhang, J., Wensuo, J., Jianchang, Y., Abdelbegi, M.I. (2006). Role of ABA in integrating plant responses to drought and salt stress. *Field Crops Research*, 97:111-119.

How to cite this article: Ezatollah Farshadfar, Mohammad Mehdi Poursiahbidi, Seyed Mehdi Safavi, Assessment of drought tolerance in land races of bread wheat based on resistance/ tolerance indices. *International Journal of Advanced Biological and Biomedical Research*, 2018, 6(4), 266-278.

Table 1: Genotype codes and names

Code	Name	Code	Name
1	WC-4537	11	WC-4889
2	Wc- 4829	12	WC-4515
3	Wc- 4536	13	WC-4780
4	Wc-4937	14	WC-4592
5	WC-4594	15	WC-4610
6	WC-4924	16	WC-4992
7	WC-4888	17	WC-4995
8	WC-4823	18	WC-4573
9	WC-4827	19	WC-Shahryar
10	WC-4582	20	WC-5047

Table 2: Resistance/tolerance indices for wheat landraces under stress and non-stress

Genotype	Yp	Ys	SSI	STI	TOL	MP	GMP	HM	YSI	YI
1	0.720	0.593	0.896	0.721	0.127	0.657	0.654	0.651	0.824	0.959
2	0.727	0.607	0.841	0.744	0.120	0.667	0.664	0.661	0.835	0.981
3	0.733	0.613	0.833	0.759	0.120	0.673	0.671	0.668	0.836	0.992
4	0.990	0.830	0.823	1.387	0.160	0.910	0.906	0.903	0.838	1.342
5	0.763	0.537	1.512	0.691	0.227	0.650	0.640	0.630	0.703	0.868
6	0.803	0.677	0.803	0.918	0.127	0.740	0.737	0.735	0.842	1.094
7	0.880	0.787	0.540	1.169	0.093	0.833	0.832	0.831	0.894	1.272
8	0.900	0.723	0.999	1.099	0.177	0.812	0.807	0.802	0.804	1.169
9	0.687	0.613	0.544	0.711	0.073	0.650	0.649	0.648	0.893	0.992
10	0.753	0.630	0.833	0.801	0.123	0.692	0.689	0.686	0.836	1.019
11	0.773	0.537	1.558	0.701	0.237	0.655	0.644	0.634	0.694	0.868
12	0.773	0.593	1.185	0.775	0.180	0.683	0.677	0.671	0.767	0.959
13	0.713	0.550	1.166	0.662	0.163	0.632	0.626	0.621	0.771	0.889
14	0.620	0.463	1.286	0.485	0.157	0.542	0.536	0.530	0.747	0.749
15	0.700	0.543	1.139	0.642	0.157	0.622	0.617	0.612	0.776	0.878
16	0.803	0.690	0.718	0.936	0.113	0.747	0.745	0.742	0.859	1.116
17	0.790	0.720	0.451	0.960	0.070	0.755	0.754	0.753	0.911	1.164
18	0.757	0.533	1.503	0.681	0.223	0.645	0.635	0.626	0.705	0.862
19	0.920	0.670	1.383	1.040	0.250	0.795	0.785	0.775	0.728	1.083
20	0.587	0.460	1.099	0.456	0.127	0.523	0.519	0.516	0.784	0.744

Table 2: Continued

Genotype	SDI	DI	RDY	ATI	SSPI	K1	K2	SNPI	RDI
1	0.176	0.791	99.996	0.067	8.228	0.875	0.920	1.376	1.026
2	0.165	0.819	99.996	0.064	7.795	0.891	0.962	1.432	1.039
3	0.164	0.829	99.996	0.065	7.795	0.908	0.983	1.452	1.041
4	0.162	1.125	99.992	0.117	10.394	1.654	1.801	1.966	1.043
5	0.297	0.610	99.996	0.117	14.724	0.984	0.753	1.080	0.875
6	0.158	0.922	99.995	0.075	8.228	1.089	1.197	1.618	1.048
7	0.106	1.137	99.993	0.062	6.063	1.307	1.618	2.118	1.112
8	0.196	0.940	99.993	0.115	11.476	1.367	1.368	1.622	1.000
9	0.107	0.886	99.996	0.038	4.764	0.796	0.983	1.652	1.112
10	0.164	0.852	99.995	0.068	8.012	0.958	1.038	1.491	1.041
11	0.306	0.602	99.996	0.123	15.374	1.009	0.753	1.072	0.864
12	0.233	0.736	99.995	0.098	11.693	1.009	0.920	1.271	0.955
13	0.229	0.686	99.996	0.082	10.610	0.859	0.791	1.184	0.960
14	0.253	0.560	99.997	0.067	10.177	0.649	0.561	0.973	0.930
15	0.224	0.682	99.996	0.078	10.177	0.827	0.772	1.177	0.966
16	0.141	0.958	99.994	0.068	7.362	1.089	1.245	1.705	1.069
17	0.089	1.061	99.994	0.042	4.547	1.053	1.355	2.052	1.134
18	0.295	0.608	99.996	0.114	14.508	0.966	0.744	1.074	0.877
19	0.272	0.789	99.994	0.158	16.240	1.429	1.173	1.375	0.906
20	0.216	0.583	99.997	0.053	8.228	0.581	0.553	1.008	0.976

Table 3: Correlation coefficients between drought tolerance indices

	YP	YS	SSI	STI	TOL	MP	GMP	HM	YSI	YI	SDI	DI	RDY	ATI	SSPI	K1STI	K2STI	SNPI	RDI
YP	1	0.86**	-0.14	0.95**	0.23	0.96**	0.95**	0.94**	0.14	0.86**	-0.14	0.68**	-0.95**	0.57**	0.23	0.99**	0.85**	0.63**	0.14
YS		1	-0.63**	0.97**	-0.3	0.96**	0.97**	0.98**	0.63**	1**	-0.63**	0.96**	-0.97**	0.08	-0.3	0.85**	0.99**	0.93**	0.62**
SSI			1	-0.42	0.92**	-0.40	-0.43	-0.46*	-1**	-0.63**	1**	-0.82**	0.42	0.71**	0.92**	-0.14	-0.61**	-0.83**	-1**
STI				1	-0.07	0.99**	0.99**	0.99**	0.42	0.97**	-0.42	0.86**	-1**	0.31	-0.07	.95**	0.97**	0.82**	0.42
TOL					1	-0.04	-0.07	-0.10	-0.92**	-0.3	0.92**	-0.56*	0.07	0.92**	1**	0.23	-0.29	-0.59**	-0.92**
MP						1	0.99**	0.99**	0.40	0.96**	-0.40	0.85**	-0.99**	0.34	-0.04	0.96**	0.96**	0.81**	0.40
GMP							1	1**	0.43	0.97**	-0.43	0.86**	-0.99**	0.31	-0.07	0.95**	0.97**	0.82**	0.43
HM								1	0.46*	0.98**	-0.45*	0.88**	-0.99**	0.27	-0.10	0.94**	0.97**	0.84**	0.45*
YSI									1	0.63**	-1**	0.82**	-0.42	-0.71**	-0.92**	0.14	0.61**	0.83**	1**
YI										1	-0.62**	0.96**	-0.97**	0.08	-0.30	.86**	0.99**	0.93**	0.62**
SDI											1	-0.82**	0.42	0.71**	0.93**	-0.14	-0.61**	-0.83**	-1**
DI												1	-0.86**	-0.21	-0.56*	0.67**	0.95**	0.99**	0.82**
RDY													1	-0.31	0.07	-0.95**	-0.97**	-0.82**	-0.42
ATI														1	0.92**	0.57**	0.08	-0.26	-0.71**
SSPI															1	0.23	-0.29	-0.59**	-0.92**
K1STI																1	0.86**	0.62**	0.14
K2STI																	1	0.92**	0.61**
SNPI																		1	0.84**
RDI																			1

*and ** Significant at 1% and 5% level of probabaility, respectively.

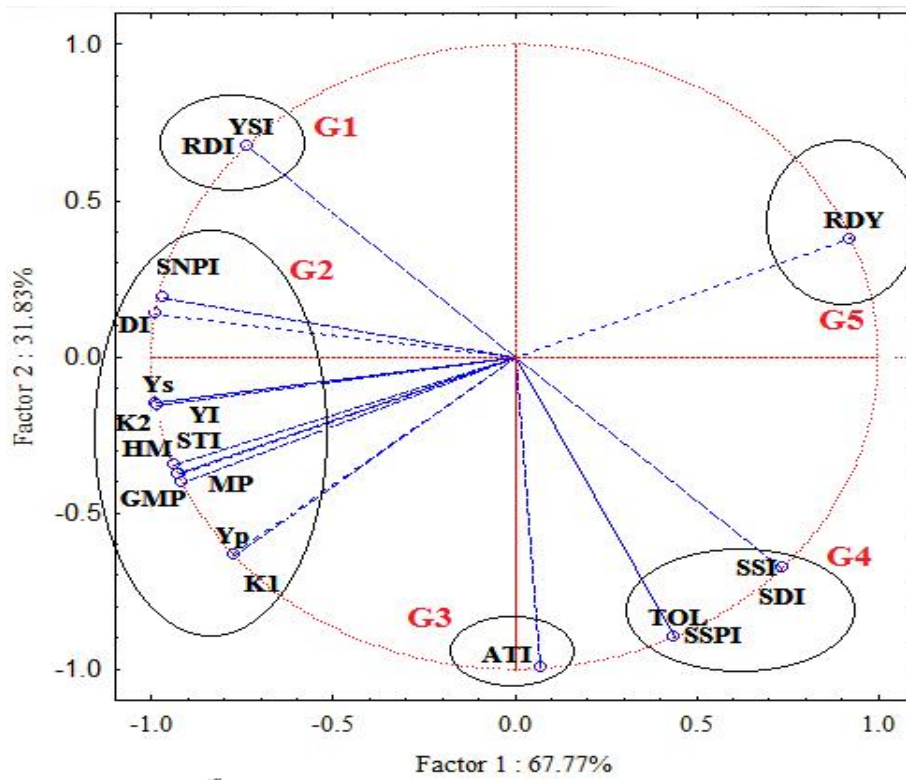

Figure 1: Biplot analysis of drought tolerance criteria in bread wheat

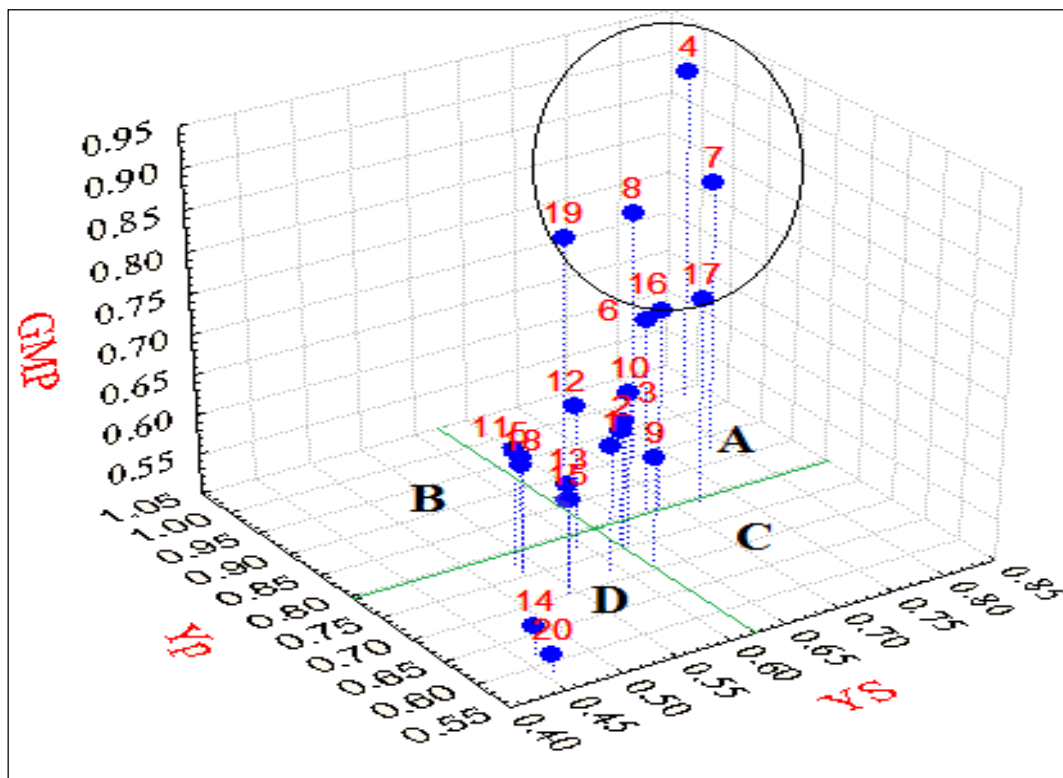

Figure 2: The three dimensional plots among GMP, Yp and Ys

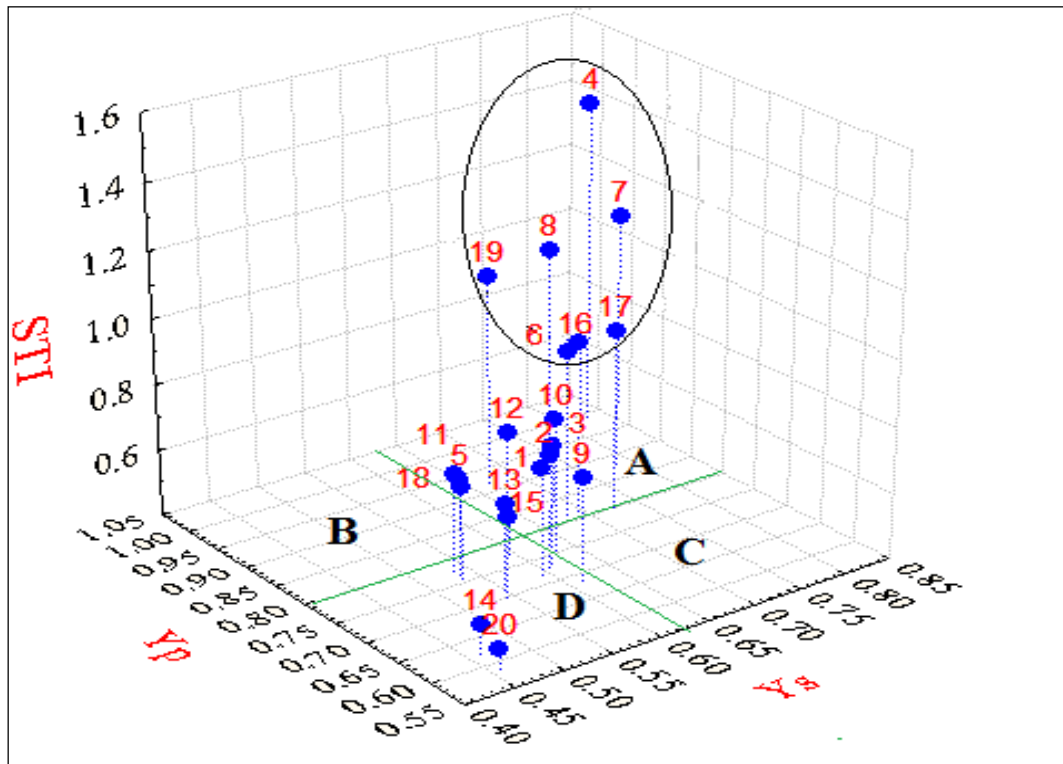

Figure 3: The three dimensional plots among STI, Yp and Ys

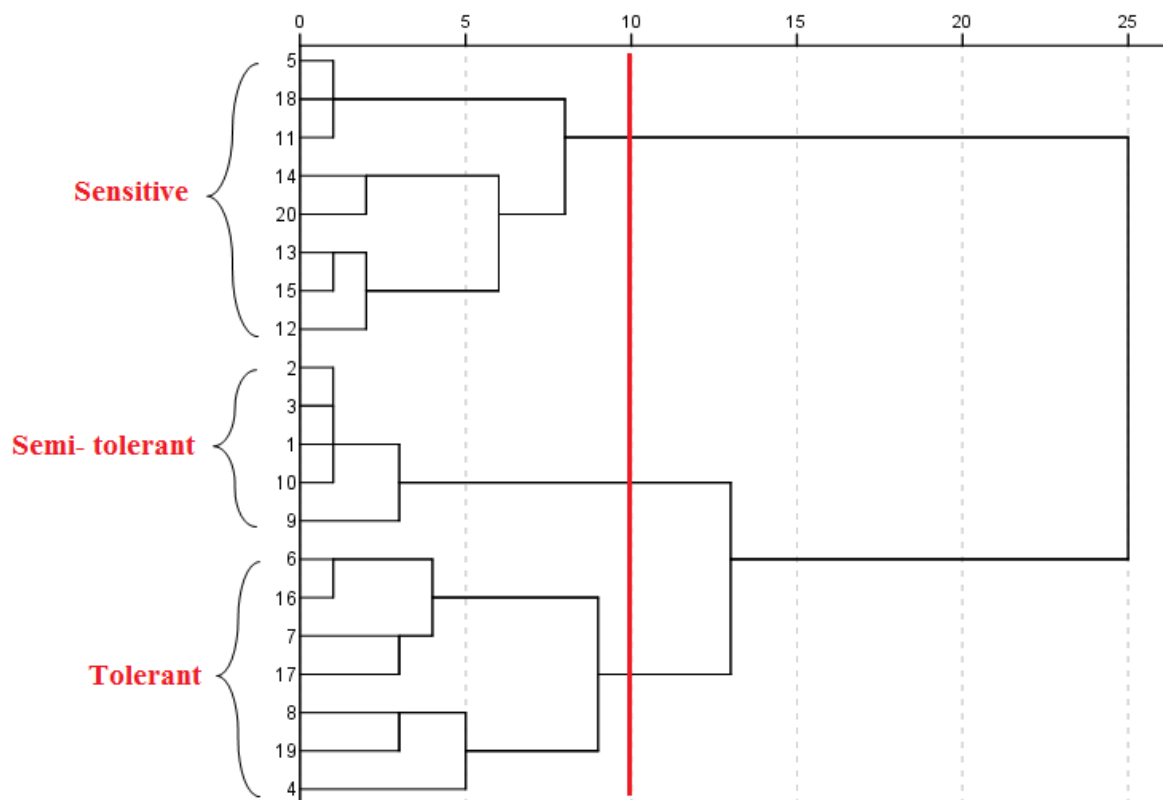

Figure 4: Dendrogram using Ward method between groups showing classification of cultivars based on resistance/tolerance indices